

AUTOGARD SERIES 400

TORQUE LIMITER ENGINEERING INFORMATION

Covers

Covers are not usually required for reasonably clean factory installations.

For protection against moderately dusty or dirty atmospheres the Autogard unit can be furnished with a dust resistant cover as shown in Figure 1 and Table 2. The dust cover incorporates a limit switch plate as shown.

Table 2

Size	Dimensions						Material
	Dc		Ec		Fc		
	(in)	(mm)	(in)	(mm)	(in)	(mm)	
1	2.9	74	2.5	64	3.25	83	Steel
2	4.7	120	3.7	94	5.5	140	Steel
3	6.1	155	5.1	130	7.25	184	Steel
4	6.9	175	5.7	145	8.00	203	Steel
5	9.1	230	7.8	198	11.0	279	Steel

Covers for exceptional applications such as high pressure wash down are available upon request – Consult Autogard.

Limit Switch Plates

The Autogard Series 400 has been designed to run for prolonged periods (dependant upon the conditions) in the disengaged position. However, it is preferable to use the slide plate movement on disengagement to operate a limit switch, which switches off the main drive and/or sounds an alarm.

The limit switch may be operated by a limit switch operating plate fitted to the slide plate or by the cover. In some circumstances a limit switch may be operated directly by the slide plate.

Table 3 and figure 2 gives details of the limit switch plate and the movement on disengagement.

Protective Finish

The standard protective finish applied to Autogard Torque Limiters is manganese phosphate plus oil dip. This treatment provides a high level of protection with good corrosion resistance and is suitable for most environments. Other finishes can be applied for situations where exceptional environments necessitate high levels of protection – Consult Autogard.

Installation Data

Maintenance

The Autogard Series 400 Torque Limiter normally uses needle thrust bearings and self-lubricating journal bearings. Both needle bearings and drive balls are packed with grease at assembly. Under reasonably clean conditions, or with the appropriate type of cover, the unit should operate properly with an annual inspection and re-greasing. The amount of maintenance required is dependent upon the operating conditions and should be maintained at least as frequently as the adjacent drive components. In adverse conditions – consult Autogard.

General Safety

The Autogard Torque Limiter is a reliable unit, built to high standards of workmanship. Similar to all mechanical devices, each application must be considered on its own merits with reference to safety (i.e. lifting equipment, explosive conditions, etc). As a rotating component, adequate guarding must be provided, in accordance with local codes. Autogard staff are always available to discuss particular applications.

Figure 1

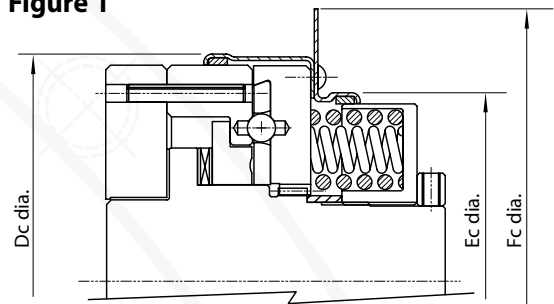

Figure 2

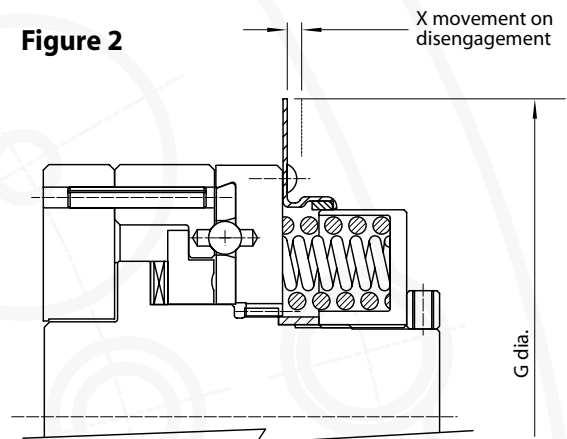

Table 3

Size		1	2	3	4	5	6
X	(in)	.059	.112	.137	.137	.173	.210
	(mm)	1.5	2.84	3.48	3.48	4.39	5.33
G	(in)	4.33	5.50	7.25	8.00	11.00	12.00
	(mm)	110	140	184	203	279	305